

6" STORM TAPS ARE TO BE PROVIDED IN BACK LOT STORM SEWERS.

18" VERTICAL & 10' HORIZONTAL SEPARATION SHALL BE MAINTAINED BETWEEN WATER LINE & SANITARY SEWER.

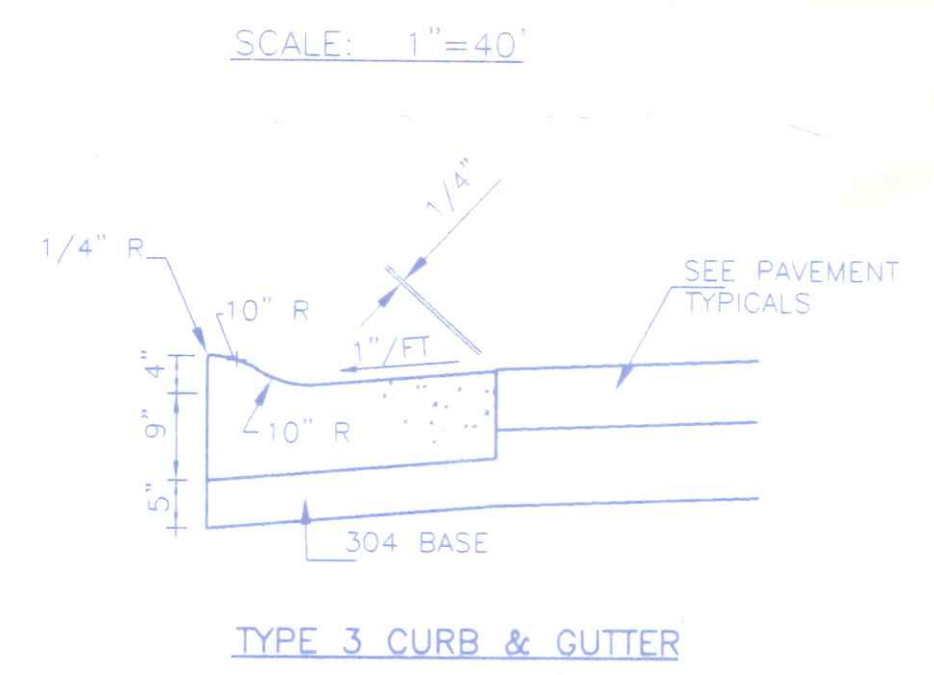
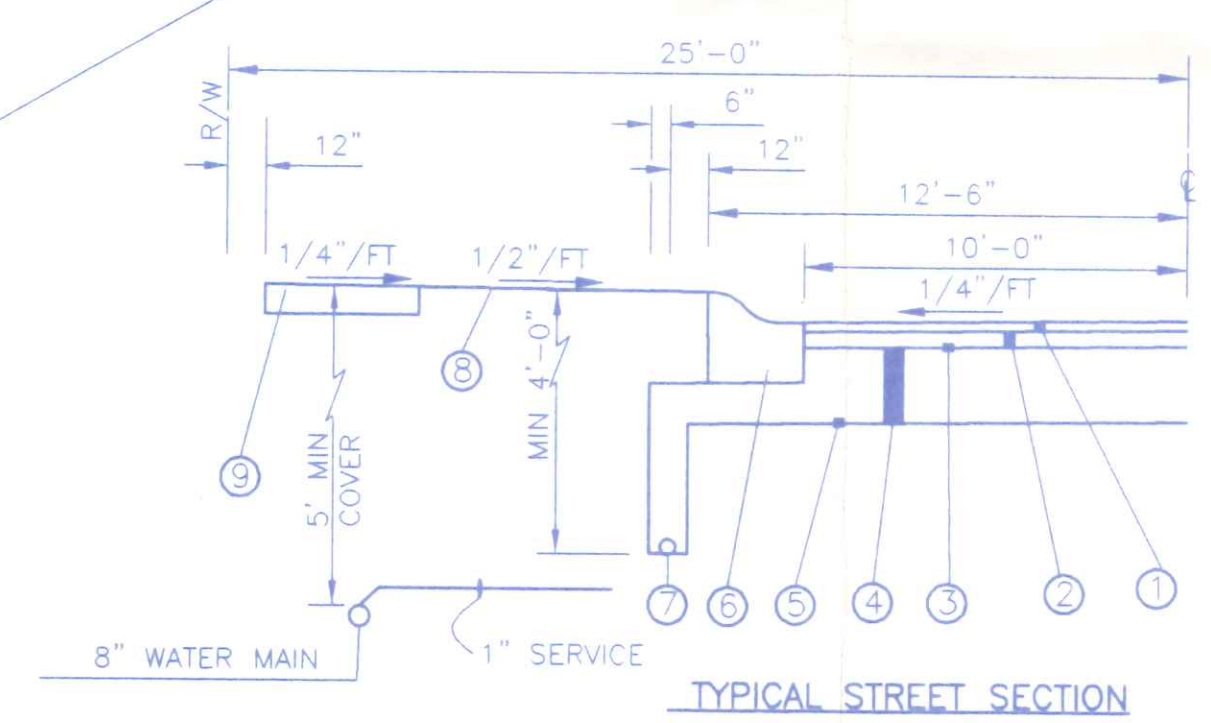

- ① 1 1/2" ODOT 404 A.C.-10
- ② 2 1/2" ODOT 402 A.C.-20
- ③ ODOT 408 PRIME COAT @ 0.25 GAL/SY
- ④ 10" ODOT 304 AGGREGATE BASE (98% OF STAND PROCTOR)
- ⑤ SUBGRADE COMPACTION 203
- ⑥ CONCRETE CURB & GUTTER ODOT TYPE 2 MED T=9"
- ⑦ 6" PERFORATED UNDERDRAIN
- ⑧ SEEDING & MULCHING
- ⑨ 4' CONCRETE SIDEWALK- BY HOME BUILDER

NOTE:
T/C IS 0.10' BELOW @ P.V.T.

**GERKEN-HOEFFEL ADD.
NAPOLEON, OHIO**

**UTILITY &
DRAINAGE PLAN**

SCALE: 1"=40' DATE: 6/28/99 DWN BY: JYIC
BRYAN ENGINEERING & SURVEYING
ANTHONY H. HOEFFEL
128 S. LYNN ST. BRYAN, OH 43506
1-419-636-2060

2
10